

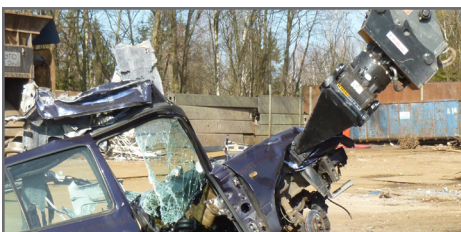

KINSHOFER
crane and excavator attachments

Pincer Grab with *HPXdrive*

Special and Custom Solutions



Pincer/2023

Pincer Grab with *HPXdrive* for excavators with 4 to 6t

The pincer grab with *HPXdrive* from **KINSHOFER** is based on the proven D06HPX demolition and sorting grab and has all the advantages of the revolutionary, patented *HPXdrive* technology. The exchangeable pincer tines are ideal for precise separation, e.g. when dismantling car wrecks.

ADVANTAGES:

- ▷ ***HPXdrive*** – the revolutionary concept for hydraulically operated grabs! The rotation of the arms of the grab is generated by two hollow shafts, which run opposed and have a helix thread, hydraulically driven by a single piston.
No hydraulic cylinder required!
- ▷ **50% longer life cycle.** The drive unit runs in a permanent oil bath – no lubrication necessary. Resistant against dirt and blows, due to the compact design.
- ▷ Including flat 10t-rotator with **360° endless rotation** for precise positioning!
- ▷ **Constant closing force** (18 kN / 3,960 lbf at 26 MPa / 3,770 psi) during the entire operation.
- ▷ Different applications possible thanks to easy **shell exchange system**.
- ▷ Robust exchangeable tips due to the use of cutting edge material 500 HB steel.

TECHNICAL DATA (drawing in mm):

Operating pressure:	max. 320 bar / 4,608 psi (internal max. 260 bar / 3,770 psi)
Load capacity:	1,000 kg / 2,200 lbs
Closing force:	18 kN / 3,960 lbf
Self weight:	310 kg / 682 lbs

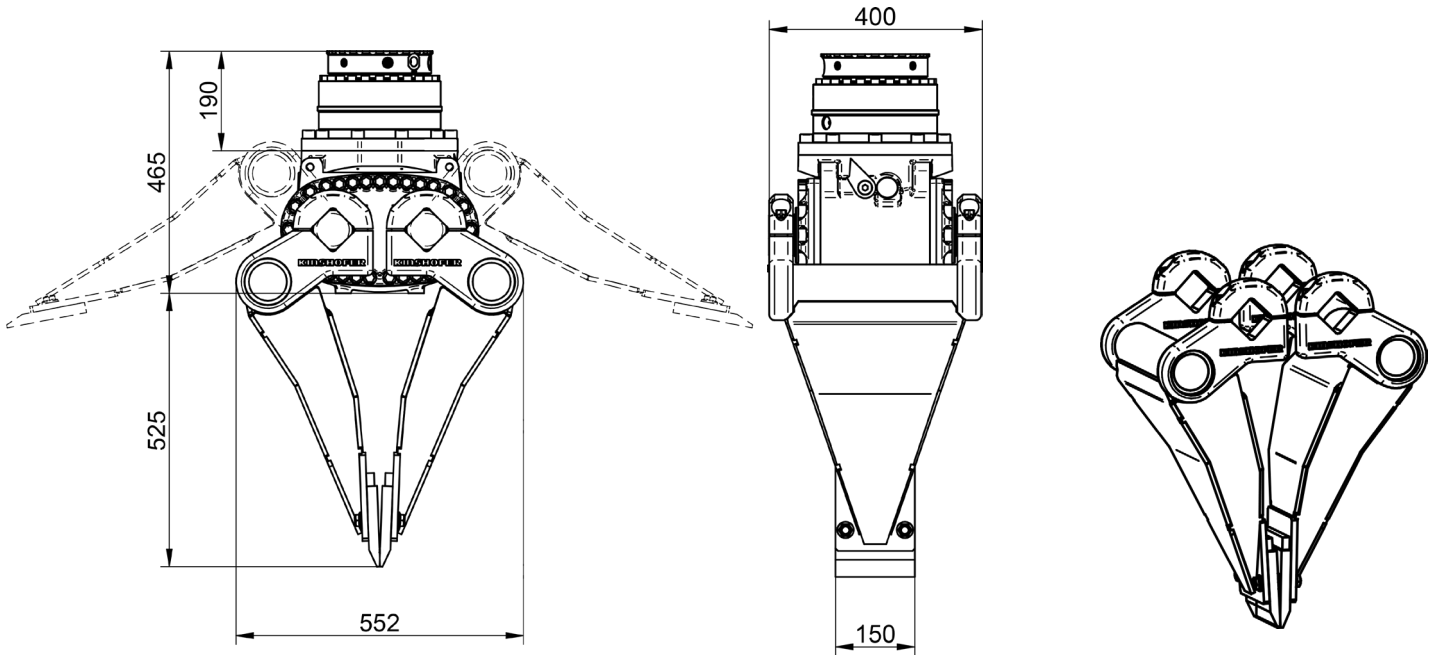

We reserve the right to amend specifications without prior notice! **KINSHOFER** GmbH, D-83607 Holzkirchen, Germany

Headquarters Germany:
KINSHOFER GmbH
Raiffeisenstrasse 12
83607 Holzkirchen
Tel.: +49 (0) 8021 88 99 0
Email: info@kinshofer.com
www.kinshofer.com



KINSHOFER is an
ISO 9001 certified Company.
DVS ZERT is a registered trademark
of DVS ZERT e.V., Düsseldorf.

